

SAFEMASTER Delay Module, Release Delay BG 7926

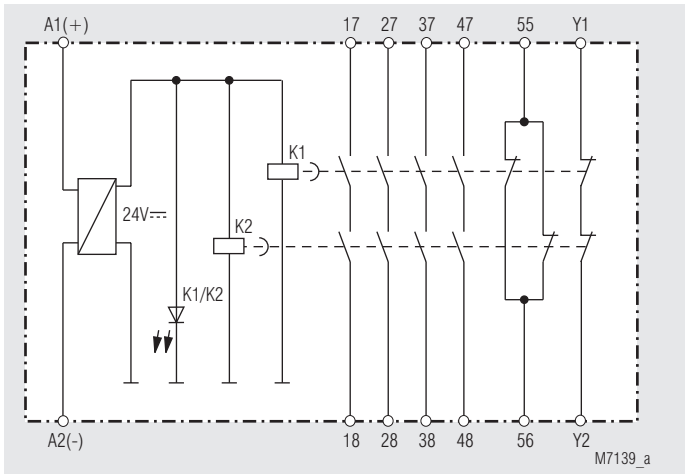

- According to
 - Performance Level (PL) d and category 2 to EN ISO 13849-1: 2008
 - SIL Claimed Level (SIL CL) 2 to IEC/EN 62061
 - Safety Integrity Level (SIL) 2 to IEC/EN 61508 and IEC/EN 61511 when connected to a suitable safety module
- Redundant and forcibly guided contacts
- 1 timing circuit
- Fixed time delay 1, 2 or 3 sec
- Without auxiliary supply
- Output: 5 NO contacts or 4 NO contacts / 1 NC contact, 1 NC contact for feed back circuit
- Indicator LED for operation
- Removable terminal strips
- Wiring diameter: also 2 x 1.5 mm² stranded ferruled with sleeve DIN 46 228-1/-2/-3/-4 or 2 x 2.5 mm² stranded ferruled DIN 46 228-1/-2/-3
- Width 22.5 mm

Block Diagrams



BG 7926.54

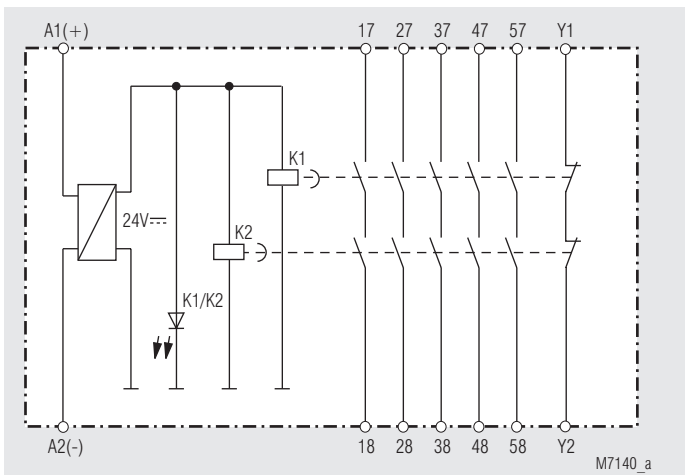

BG 7926.60

Approvals and Marking



* see variants

Application

Delayed disconnection of safety relevant circuits, stop category 1 according to IEC/EN 60 204-1.

Indicator

LED K1/K2: On, when control voltage applied

Notes

Attention!



To achieve the safety levels stated under features, the supervising control (e.g. BG 5924) must check the NC contact Y1/Y2 before starting to make sure that both relays (K1 and K2) are switched off.

Circuit Diagrams

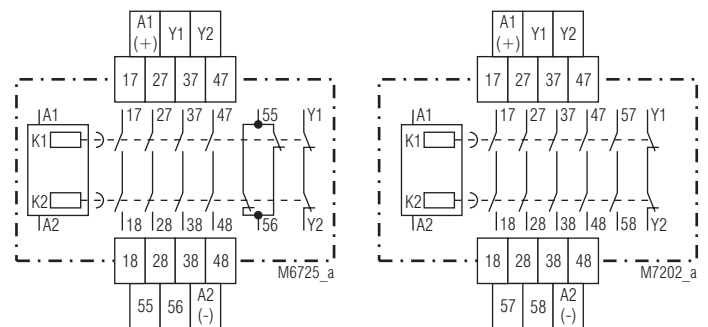

BG 7926.54

BG 7926.60

Technical Data

Time circuit

Release time:	1 s; 2 s; 3 s fixed other times on request
Time accuracy:	30 %
Repeat accuracy:	± 5 % of nominal value
Min. closing time:	200 % of nominal value

Input

Nominal voltage U_N:	AC/DC 24 V
Voltage range:	AC 0.8 ... 1.1 U_N
at 10 % residual ripple:	DC 0.9 ... 1.1 U_N
at 48 % residual ripple:	DC 0.8 ... 1.1 U_N
Nominal consumption	
AC 24 V:	2.1 VA
DC 24 V:	3 W
Nominal frequency:	50 / 60 Hz
Control current	
AC 24 V:	100 mA
DC 24 V:	120 mA

Output

Contacts		
BG 7926.60:	5 NO contacts, 1 NC contact for feed back circuit	
BG 7926.54:	4 NO contacts, 1 NC contact, 1 NC contact for feed back circuit	
Response time:	max. 20 ms	
Release time:	1 s, 2 s, 3 s	
Type of contact:	relay, forcibly guided	
Nominal output voltage:	AC 250 V	
Thermal current I_{th}:	max. 5 A (see total current limit curve)	
Switching capacity		
to AC 15		
NO contact:	3 A / AC 230 V	IEC/EN 60 947-5-1
NC contact:	2 A / AC 230 V	IEC/EN 60 947-5-1
to DC 13		
NO contact:	1 A / DC 24 V	IEC/EN 60 947-5-1
NC contact:	1 A / DC 24 V	IEC/EN 60 947-5-1
to DC 13		
NO contact:	4 A / 24 V at 0.1 Hz	
NC contact:	4 A / 24 V at 0.1 Hz	
Electrical life		IEC/EN 60 947-5-1
to AC 15 at 2 A, AC 230 V:	10 ⁵ switching cycles	
Permissible switching frequency:	600 switching cycles / h	
Short circuit strength		
max. fuse rating:	4 A gL	IEC/EN 60 947-5-1
line circuit breaker:	C8A	
Mechanical life:	10 x 10 ⁶ switching cycles	

General Data

Operating mode:	Continuous operation	
Temperature range:	- 15 ... + 55°C	
Clearance and creepage distances		
rated impuls voltage / pollution degree:	4 kV / 2 (basis insulation)	IEC 60 664-1
EMC		
Electrostatic discharge:	8 kV (air)	IEC/EN 61 000-4-2
HF-irradiation:	10 V / m	IEC/EN 61 000-4-3
Fast transients:	4 kV	IEC/EN 61 000-4-4
Surge voltages between wires for power supply:	1 kV	IEC/EN 61 000-4-5
between wires and ground:	4 kV	IEC/EN 61 000-4-5
HF-wire guided:	10 V	IEC/EN 61 000-4-6
Interference suppression:	Limit value class B	EN 55011
Degree of protection		
Housing:	IP 40	IEC/EN 60 529
Terminal plate:	IP 20	IEC/EN 60 529
Housing:	Thermoplastic with V0-behaviour according to UL subject 94	
Vibration resistance:	Amplitude 0.35 mm Frequenz 10 ... 55 Hz,	IEC/EN 60 068-2-6
Climate resistance:	15 / 055 / 04	IEC/EN 60 068-1

Technical Data

Wire connection:	1 x 4 mm ² solid or 1 x 2.5 mm ² stranded ferruled with sleeve or 2 x 1.5 mm ² stranded ferruled with sleeve DIN 46 228-1/-2/-3/-4 or 2 x 2.5 mm ² stranded ferruled DIN 46 228-1/-2/-3
Wire connection:	Plus-Minus terminal screws M3.5 Box terminals with wire protection
Mounting:	DIN rail IEC/EN 60 715
Weight:	180 g

Dimensions

Width x height x depth:	22.5 x 84 x 121 mm
--------------------------------	--------------------

Safety Related Data

Values according to EN ISO 13849-1:

Category:	2	
PL:	d	
MTTF _d :	142.1	a (years)
DC _{avg} :	98.2	%
d _{op} :	365	d/a (days/year)
h _{op} :	24	h/d (hours/day)
t _{cycle} :	3600	s/Zyklus
	≅ 1	/h (hour)

Values according to IEC/EN 62061 / IEC/EN 61508 / IEC/EN 61511:

SIL CL:	2	IEC/EN 62061
SIL:	2	IEC/EN 61508 / IEC/EN 61511
HFT ¹⁾ :	0	
DC _{avg} :	98.2	%
SFF:	99.4	%
PFH _D :	1.26E-08	h ⁻¹
PFD:	5.41E-05	
T ₁ :	20	a (years)

¹⁾ HFT = Hardware-Failure Tolerance



The values stated above are valid for the standard type.
Safety data for other variants are available on request.

The safety relevant data of the complete system has to be
determined by the manufacturer of the system.

UL-Data

The safety functions were not evaluated by UL. Listing is accomplished according to requirements of Standard UL 508, "general use applications"

Nominal voltage U_N:	AC/DC 24 V
Ambient temperature:	-15 ... +50°C,
Switching capacity	
NO contact :	Pilot duty B300 5A 250Vac Resistive 5A 24Vdc Resistive or G.P.
NC contact:	5A 250Vac Resistive 5A 24Vdc Resistive or G.P.
Wire connection:	60°C / 75°C copper conductors only AWG 20 - 12 Sol Torque 0.8 Nm AWG 20 - 14 Str Torque 0.8 Nm



Technical data that is not stated in the UL-Data, can be found
in the technical data section.

Standard Type

BG 7926.60 3 s AC/DC 24 V 50/60 Hz
 Article number: 0050808
 • Output: 5 NO contacts, 1 NC contact for feed back circuit
 • Release time: 3 s
 • Nominal voltage U_N : AC/DC 24 V
 • Width: 22.5 mm

Ordering Example

BG 7926 .60 3 s AC/DC 24 V 50 / 60 Hz

_____ Nominal frequency
 _____ Nominal voltage
 _____ Release time
 _____ Contacts
 _____ Type

Variant

BG 7926/61: with UL-approval

Characteristic

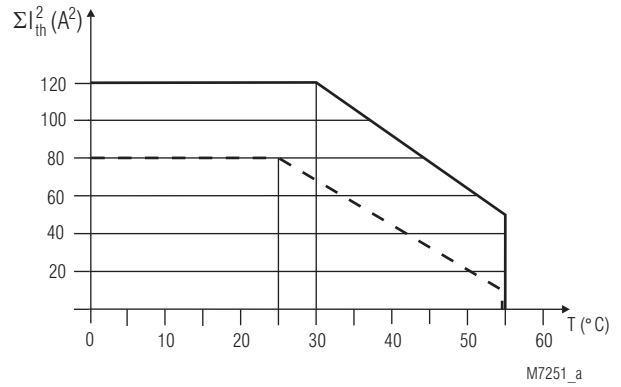

— AC / DC 24 V device mounted on distance with aircondition
 - - - AC / DC 24 V device mounted without distances heated by devices with same load

quadratic total current

$$\Sigma I_{th}^2 = I_{th1}^2 + I_{th2}^2 + I_{th3}^2 + I_{th4}^2 + I_{th5}^2$$

I_{th1} , I_{th2} , I_{th3} , I_{th4} , I_{th5} : thermal current I_{th} on contact rows

Total current limit curve

Application Example

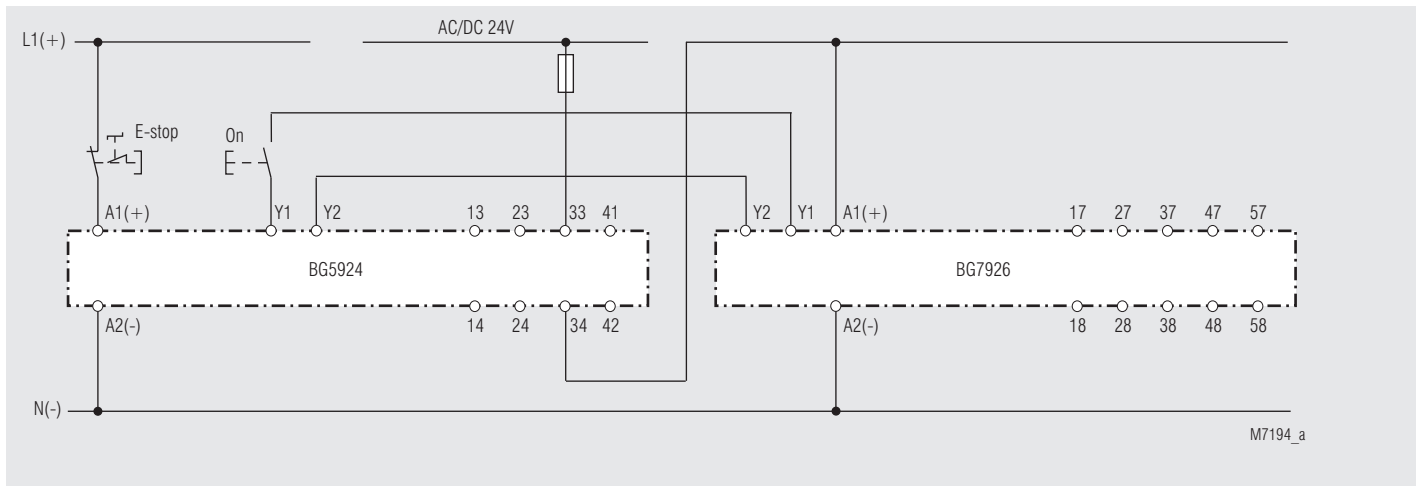

Multiplication of contacts at single channel E-stop circuit with feedback loop.
 Suited up to SIL2, Performance Level d, Cat. 2

